

ROCONVERT**72.01 E³****Battery Conversion Kit****EASY CONVERSION TO
BLDC ELECTRIC MOTOR.**

ROWRENCH 30.82HKS
 ROCONVERT 72.01 - 5819900001
 ROBATTERY 71.02 (2300 Wh) - 7839900001

The alternative to new investment.**THE ADVANTAGES. YOUR BENEFITS.****Extended operational range**

- BLDC electric motor, in particular for tunnels and urban areas
- Maximum flexibility due to various types of drive (battery or power supply)

Benefits for environment and budget

- Cost savings from conversion instead of new purchase
- Increased availability due to reduced drive maintenance

Pleasant working for the operator

- Very fast availability (at the push of a button)
- Reduced noise emissions
- Reduced hand-arm vibrations

SPECIFICATION

Type	BLDC electric motor
Output	4.0 kW
Expansion possible	30.82 & 30.82HKS (with Honda GX 200 or electric motor 400V, 50Hz)
Number of wrenching cycles	approx. 1000 wrenching cycles per charge of 2300 Wh battery (*)
Expansion possible	34.01 (with Honda GX 200)
Clipping time	approx. 90 min clipping time per charge of 2300 Wh battery (*)
Dimensions (L x W x H)	500 x 400 x 450 mm
Weight	
Battery conversion kit	17.5 kg
Battery 2300 Wh	16.0 kg
400 Volt power supply	18.0 kg

(*) Depending on type of track, condition of track, torque required etc.

ACCESSORIES

- 7839900001 Battery 2300 Wh
- 7879900001 Charger for battery 2300 Wh
- 5039900003 Power supply, 400 Volt – 60 Volt (incl. shoulder strap)

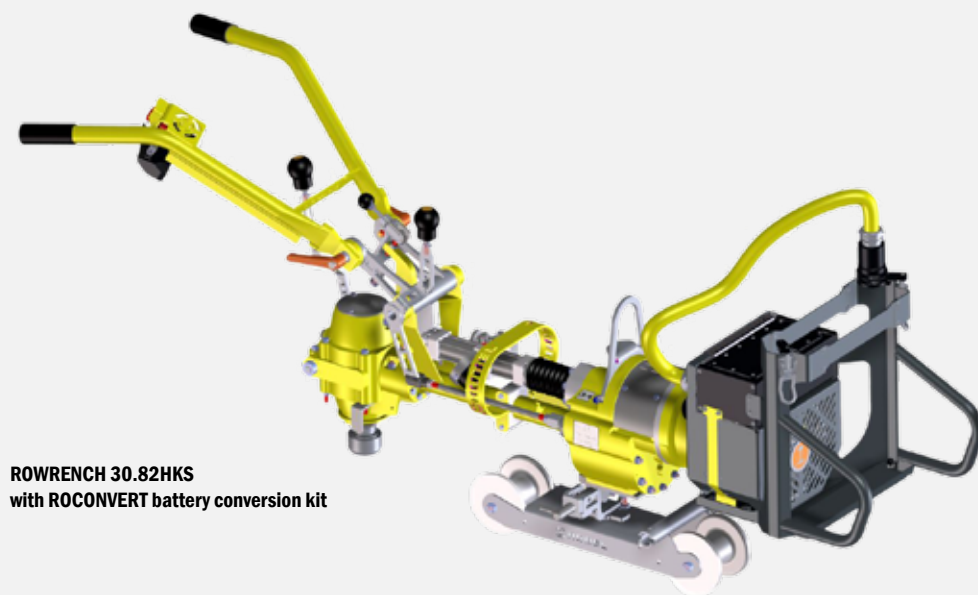

RORENTCH 30.82HKS
with ROCONVERT battery conversion kit



Battery 2300 Wh -
7839900001

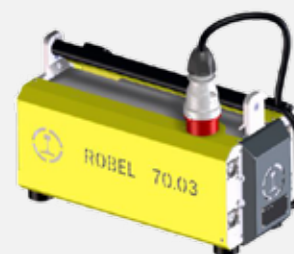

400 Volt power supply -
5039900003

**We will be happy to convert your machine in Freilassing.
You are interested in purchasing a new battery powered machine?
Please get in touch with your ROBEL contact for further information.**